

Enamelled domestic hot water tank with fixed high-capacity heat exchanger for heat pump systems

Calor TANK 200 L

Double XL Heat Exchanger



Product details

CALOR TANK



Years
Warranty



Oversized Heat
Exchanger



Premium
Glazing



Totalcalor
Base



Nominal
Pressure



Art. 4.3 PED
2014/68/EU

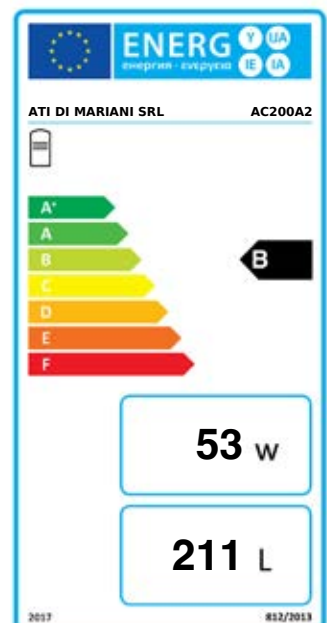

Code **AC200A2**
Price **€ 1.490,00**

Main characteristics

- Domestic hot water (DHW) storage
- Hydraulic connections on both sides
- Internal enamelled coating
- Magnesium anode
- Rigid polyurethane foam insulation
- Galvanized and plastic-coated steel casing
- Resistant to external agents
- Inspection flange
- Auxiliary electric heating element
- 5-year warranty

Technical Data		
Capacity	L	211
Empty weight	kg	79,8
Maximum water pressure	kPa (bar)	10
Energy efficiency class	ERP	B
Upper Heat Exchange Surface	m ²	1,8
Lower Heat Exchange Surface	m ²	1,2
Packaging		
Wooden crate L x W x H – (weight)	cm - (kg)	78x78x120 - (95)

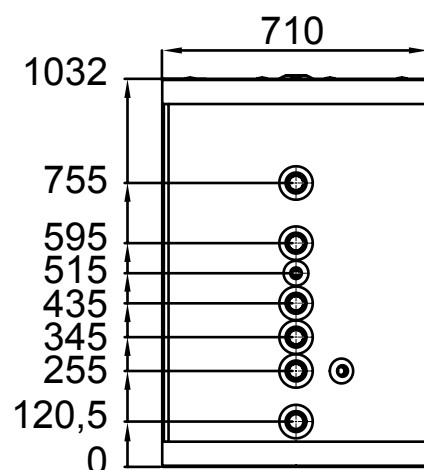
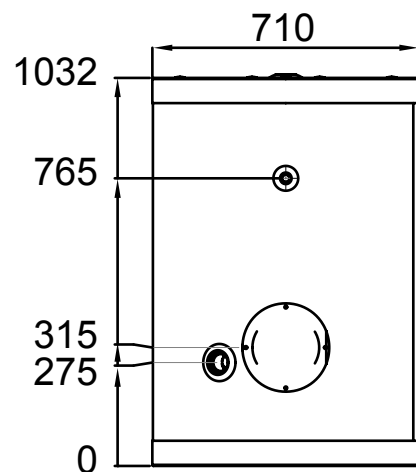

CALOR TANK

Accessories



MONOPHASE 230 V
1500 W

Code
KITAC015

Price
€ 300,00



MONOPHASE 230 V
2000 W

Code
KITAC020

Price
€ 310,00



MONOPHASE 230 V
3000 W

Code
KITAC030

Price
€ 320,00



THREEPHASE 400 V
4000 W

Code
KITAC440

Price
€ 400,00



THREEPHASE 400 V
5000 W

Code
KITAC450

Price
€ 410,00



THREEPHASE 400 V
6000 W

Code
KITAC460

Price
€ 430,00

